



Heyco® Lockit™ Strain Relief Preassembly Equipment

Mitigate carpal tunnel syndrome!



Headlock™ 1000

Assembly head for ST-100N and ST-101N Strain Reliefs. Simply place a Lockit Strain Relief into the "U" opening of the assembly head. Then place the cable into the bushing body and close the head to secure Lockit permanently onto the wire. This completed subassembly can then be installed with fingertip pressure into the application's mounting hole—at a later time, in a different place, for lower installed cost!

Autolock™ 3000

Semi-automatic assembly machine for all Lockit Strain Reliefs. Suitable for high volume production runs, where batched subassemblies are desirable. Includes vibratory feeder bowl, track and head. The operator simply inserts the cable into the assembly head slot, then presses the foot pedal to secure Lockit permanently onto the wire. These completed subassemblies can be installed with fingertip pressure into the application's mounting hole—at a later time, in a different place, for lower installed cost!

Autolock™ 2000

Assembly machine for ST-100N Strain Reliefs. This foot pedal activated assembly machine is identical to Autolock 3000, except that the gravity fed track is loaded by hand instead of by a vibratory bowl.

Autolock™ 3000-101AT

Same as Autolock 3000 except used for the ST-101A.

Assembly Equipment for **ST-201N** also available.

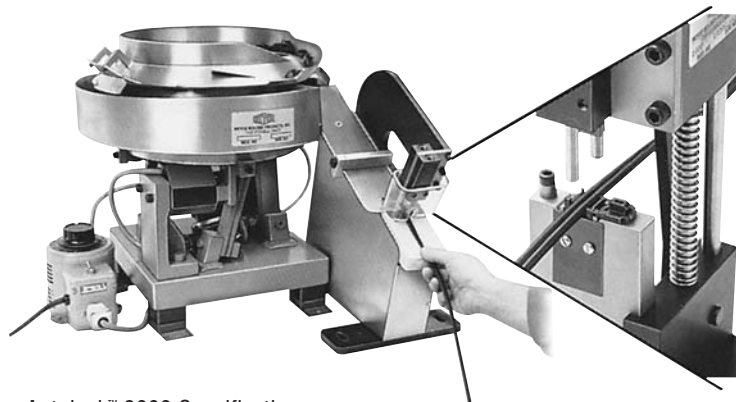

Autolock™ 3000 Specifications:
Air Pressure Required—80 to 120 psi
Electrical Required—10 amps, 120 volts, 60Hz

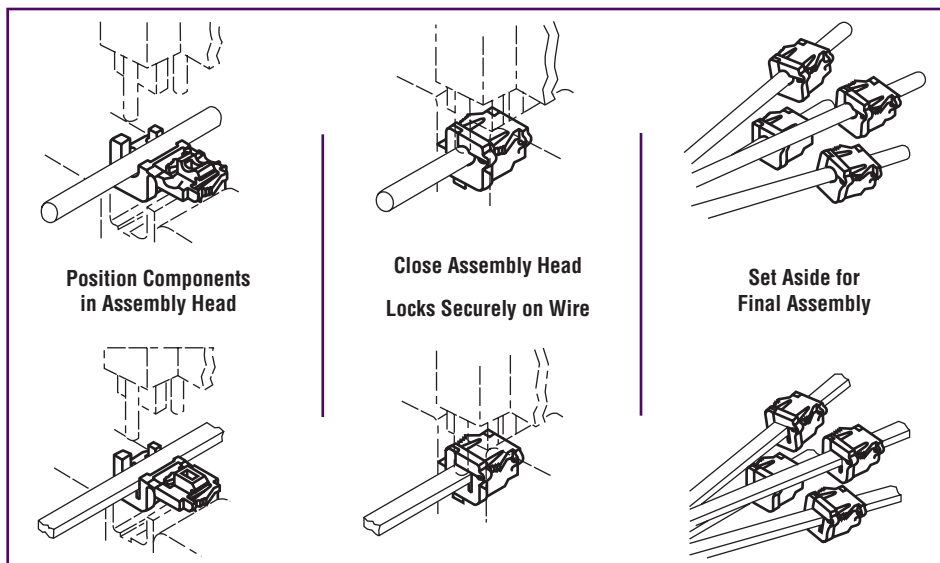

Heyconomic Pliers

Part No. 0020

Hand plier designed specifically for Lockit Strain Relief Bushings.

