

Tinnerman® Plastic Fasteners

The dimensions of the above parts are envelope dimensions only. For complete design information, please request a blueprint from your Tinnerman representative or the Tinnerman Engineering department.

Metric parts listed in italic



Button Head Dart Fasteners

Button Head Dart Fasteners. These versatile plastic fasteners offer many diversified application possibilities. They may be used for light retention, as bumpers, hole plugs, bearings or spacers. Ideally suited for simplified assembly of products shipped knocked-down for consumer assembly. Available in different materials, head types and panel ranges.

In addition to the inherent advantage of being corrosion-proof, **Button Head Darts** are shock and vibration resistant, and will not work loose.

How to apply Button Head Dart Fasteners

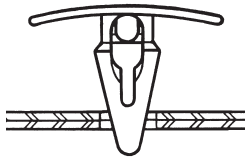

Position **Button Head** in mounting hole of panels or components to be secured.

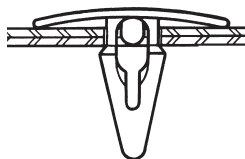

The tapered **Dart** guides panels into alignment as it is seated, leaving only the smooth **Button Head** exposed.

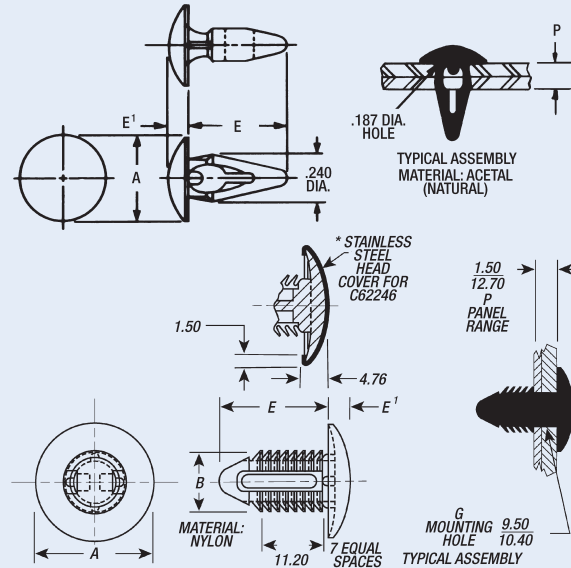

P Panel Range	Des. Var.	A	E	E1	Material (Natural)	Part Number
.035-.100	Std.	.420	.475	.100	Polypropylene	C61546AD-028
	Std.	.420	.475	.100	Acetal	C61546AG-028
	A	.305	.475	.050	Acetal	C62182AG-035
	B	.562	.475	.055	Nylon	C61809AA-035
1.520-2.540	A	11.310	15.110	1.580	Nylon	C62366AA-152M
.060-.100	A	.445	.595	.062	Nylon	C61782AA-060
.130-.180	Std.	.420	.555	.100	Nylon	C61622AA-130
	Std.	.420	.555	.100	Acetal	C61622AG-130
.170-.234	A	.420	.595	.050	Nylon	C61375AA-170
	A	.420	.595	.050	Acetal	C61375AG-170
	A	.445	.595	.062	Nylon	C61612AA-170
	A	.445	.595	.062	Polypropylene	C61612AD-170
	A	.445	.595	.062	Nylon	C61758AA-170
	A	.445	.595	.062	Acetal	C61758AG-170