

**Material:** All parts are **Spring Steel**, heat treated, unless otherwise specified.  
 The only variations available are those shown with suffix letters in the part number.  
 SS – Stainless Steel BE – Beryllium Copper P – Phosphor Bronze



## Dart-Type Fasteners

Tinnerman **Dart-Type Fasteners** are one of a group of **Speed Clip Fasteners** which are self-sufficient. That is, they require no screws, rivets, studs, welds or other secondary fastening devices. They require only a cavity or mounting hole. They can be applied from the front or top of a panel thereby eliminating many blind or limited access fastening problems. Being one-piece, they eliminate excessive small parts handling and parts inventories.

Once applied, live spring tension secures the components between the top and shoulders of the clip. The amount of clamping action here varies with the material thickness and design of the fastener. When required, most **Dart-Type Speed Clips** can be removed and reused.

### How to apply Dart-Type Speed Clip Fasteners

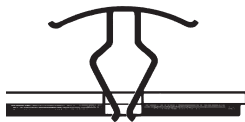

Position **Dart-Type** in mounting hole of panels or components to be secured.



As the clip is pushed into the mounting hole, spring arms compress.

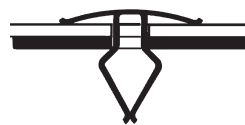

As the shoulders clear the panels they expand. This constant attempt to regain its original shape develops live spring tension between the shoulders and the top of the clip – securing the panels between.

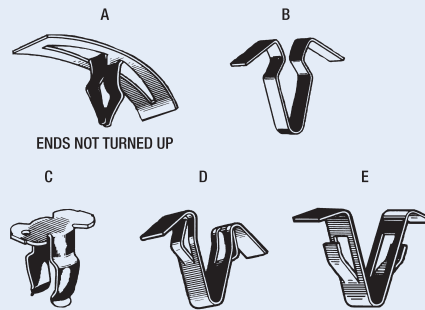
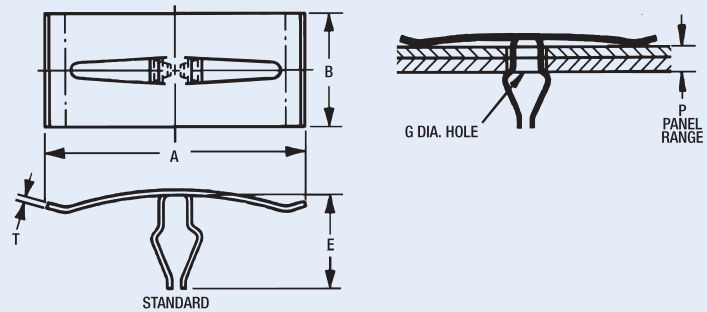

P Panel Range	Design Variation	A Length	B Width	E Height	G Panel Hole Dia.	T Mat'l. Thick.	Part Number
.031-.041	C	.550	.310	.500	.182-.192	.014	C29943-014
.050-.075	C	.550	.340	.490	.182-.192	.014	C22149-014
.050-.090	B	.875	.187	.400	.245-.255	.014	C57973-014
.054-.086	Std.	1.720	.340	.650	.186-.191	.014	C22395SS-014
.075-.150	A	1.050	.310	.390	.182-.192	.022	C3860-022
.093-.110	B	.410	.130	.560	.182-.192	.020	C26740-020
.095-.140	D	1.080	.220	.550	.307-.317	.017	C4792-017
.120-.130	C	.630	.190	.530	.213-.223	.022	C4925-022
.140-.160	B	.760	.130	.540	.182-.192	.014	C24258-014
.165-.185	Std.	1.690	.340	.620	.187-.192	.020	C4789-020
.185-.234	Std.	1.700	.340	.610	.187-.192	.017	C40617-017
.192-.212	B	.750	.130	.590	.182-.192	.014	C3822-014
.224-.244	C	.750	.310	.640	.307-.317	.025	C20341-025
.300-.400	Std.	1.700	.340	.590	.213-.223	.020	C43142SS-020